

VEHICLE Nissan Patrol Y62
PRODUCT Recovery Point
PART NUMBER RP-PAT62

FEA Rated to 5000kgs per tow point
Australian Design Registration - 201810098

Ensure all supplied and specified components are used during the installation of tow points. Failure to do so will significantly reduce the Working Load Lim-it (WLL) specified for each individual point (5000kgs), which can result in serious injury or death.

The RP-PAT62 points have been designed for fitment on a vehicle with factory standard bumper. If a Bull Bar is fitted modifications might be required to the bar bracket, and/or additional hardware might be re-quired (longer bolts etc.) to facilitate fitment. **WILL NOT SUIT WITH TJM BAR.**

Hardware Supplied with RP-PAT62

6x Washers 12mm ID, 25mm OD x 3mm thick	2x 12mm nyloc nuts	2x Spacer plate 87 x 45 x 6
2x 12mm bolts x 140mm long	2x 18mm nyloc nuts	2x Spacer plate 87 x 45 x 4
2x Washers 18mm ID, 40mm OD x 3mm thick	2x Washers 12mm ID, 36 OD x 4mm thick	1x LH recovery point
4x 12mm bolts x 50mm long flanged head	2x Captive nut side plates	1x RH recovery point
2x 12mm bolts x 65mm long hex head	2x Pin bolt 18 x 1.5	
6x Spring washers 12mm	2x Front chassis plates 50 x 125 x 10	

1. Remove the factory steel skid brackets using a 18mm socket and dispose.
2. Remove the 3 bolts that secure the inner guard to the front bumper using 10mm socket—retain.
3. Die grind this overlapping section under the front body mount making full access to the hole in the chassis behind it.



VEHICLE Nissan Patrol Y62
 PRODUCT Recovery Point
 PART NUMBER RP-PAT62

FEA Rated to 5000kgs per tow point
 Australian Design Registration - 201810098

4. Select the captive nut plate. On one side of the plate the captive nut protrudes through the plate, this is to locate into a factory hole on the inside of the chassis inline with the radiator, slide the plate up until the protruding section sits into the hole.
5. Fit the threaded pin bolt through the newly relieved hole from the outside of the chassis and thread into the captive nut plate.
6. From the front of the chassis use M12x140 bolt with flat washer & large end plate, Install the M12 bolt into the pin bolt.
7. If fitting with factory bumper discard the m12x140mm bolt and chassis end plate.
8. Using the appropriate side recovery point, place over the top of the pin bolt and loosely fit the M18 heavy duty washer and M18 nyloc nut.
9. Using 2x M12x50mm flanged head bolt and washers secure the bottom of the recovery point into the vehicles cross member but do not tighten at the stage. Depending on your vehicle you may need to use the 2 bolt spacer plates that are in the kit, these are in 2 thicknesses, the 6mm and 4mm can be used consecutively.
10. At the back of the mount use the M12x65mm bolt, black 40mm OD x 4mm heavy duty washer and nyloc nut with the machined spigot from the back of the factory tow loop. You will need to use the large 4mm thick round washers that are also provided in the kit as spacers, the gap will determine how many washers you will use.
11. Once all bolts are in and the recovery point fitted snug do all bolts up, as per the specs below.

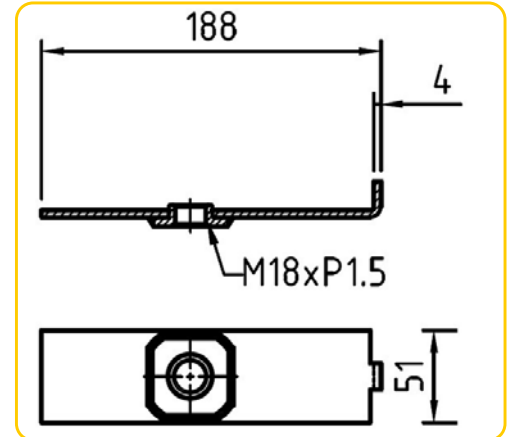

Hint: Mark the end of the pin showing orientation of the threaded hole, this helps when its in the chassis and fitment of m12x140mm bolt from the front of the chassis.



	8.8	10.9	12.9
M10	41-60 Nm	59-85 Nm	65-94 Nm
M12	71-105 Nm	102-150 Nm	114-164 Nm
M14	112-168 Nm	161-240 Nm	182-265 Nm
M16	175-260 Nm	250-371 Nm	282-406 Nm



FIGURE 5

VEHICLE Nissan Patrol Y62
PRODUCT Recovery Point
PART NUMBER RP-PAT62

FEA Rated to 5000kgs per tow point
Australian Design Registration - 201810098

THIS SHOWS FITMENT WITH ARB BAR



Pic 6. A brake away view of the M12x140 bolt in from the front of the chassis. This is missing the front chassis plate for illustration purposes.

FITTING SUPPLIMENT FOR OPPOSITE LOCK BAR

The Opposite Lock bar requires a small cut to provide clearance for fitment of the RP-PAT62 points. Both sides are the same in a mirror image.

- Mark a line from corner A to corner B
- Measure up 30mm and mark a line parallel with the bottom edge.
- From the back edge measure in to the chassis and mark a line underneath in line with the edge of the chassis.
- The tow point will slide into this recess once removed.

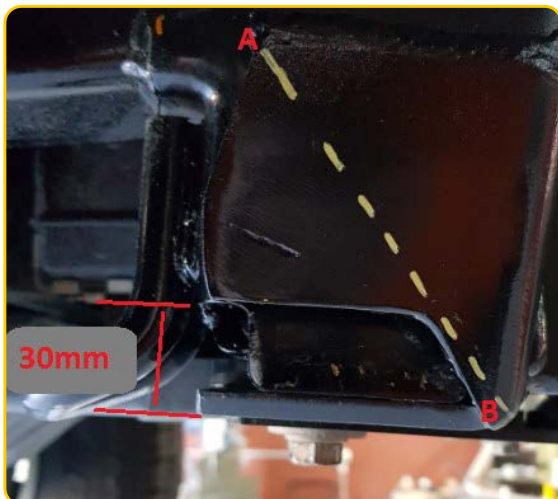

VEHICLE Nissan Patrol Y62
PRODUCT Recovery Point
PART NUMBER RP-PAT62

FEA Rated to 5000kgs per tow point
Australian Design Registration - 201810098

FITTING SUPPLEMENT FOR SERIES 5 TiL MODELS ONLY

Series 5 TiL models will require a small modification by using a linisher or angle grinder. Please see diagrams on how to achieve this. The top edge of the plate at the thinnest point needs to be 12mm thick, and on an even gradient down to the top of the oval hole.

