



**RP-PAT62**  
*Australian Design Registration—201810098*  
**Nissan Patrol Y62**  
**FEA Rated to 5000kgs**  
**per tow point**

Installation video can be found online at...

<http://roadsafe.com.au/4wd/fitting-instructions/>

**Ensure all supplied and specified components are used during the installation of tow points. Failure to do so will significantly reduce the Working Load Limit (WLL) specified for each individual point (5000kgs), which can result in serious injury or death.**

**RP-PAT62 FITMENT GUIDE—Page 1**

**The RP-PAT62 points have been designed for fitment on a vehicle with factory standard bumper. If a Bull Bar is fitted modifications might be required to the bar bracket, and/or additional hardware might be required (longer bolts etc.) to facilitate fitment.**



- Hardware Supplied with RP-PAT62**
- 6 x washers 12mm ID, 25mm OD x 3mm thick
  - 2 x 12mm bolts x 140mm long
  - 2 x washers 18mm ID, 40mm OD x 3mm thick
  - 4 x 12mm bolts x 50mm long flanged head
  - 2 x 12mm bolts x 65mm long hex head
  - 6 x Spring washers 12mm
  - 2 x 12mm nyloc nuts
  - 2 x 18mm nyloc nuts
  - 2 x washers 12mm ID, 36 OD x 4mm thick
  - 2 x captive nut side plates
  - 2 x pin bolt 18 x 1.5
  - 2 x front chassis plates 50 x 125 x 10
  - 2 x spacer plate 87 x 45 x 6
  - 2x spacer plate 87 x 45 x 4
  - 1 x LH recovery point
  - 1 x RH recovery point

1. Remove the factory steel skid brackets using a 18mm socket and dispose.
2. Remove the 3 bolts that secure the inner guard to the front bumper using 10mm socket—retain.



3. Die grind this overlapping section under the front body mount making full access to the hole in the chassis behind it.





**RP-PAT62**  
*Australian Design Registration -201810098*  
**Nissan Patrol Y62**  
**FEA Rated to 5000kgs**  
**per tow point**

**RP-PAT62 FITMENT GUIDE—Page 2**

4. Select the captive nut plate. On one side of the plate the captive nut protrudes through the plate, this is to locate into a factory hole on the inside of the chassis inline with the radiator, slide the plate up until the protruding section sits into the hole.
5. Fit the threaded pin bolt through the newly relieved hole from the outside of the chassis and thread into the captive nut plate. \*See hint
6. From the front of the chassis use M12x140 bolt with flat washer & large end plate, Install the M12 bolt into the pin bolt. See pic #6
7. (If fitting with factory bumper discard the m12x140mm bolt and chassis end plate)
8. Using the appropriate side recovery point, place over the top of the pin bolt and loosely fit the M18 heavy duty washer and M18 nyloc nut.
9. Using 2x M12x50mm flanged head bolt and washers secure the bottom of the recovery point into the vehicles cross member but do not tighten at the stage. Depending on your vehicle you may need to use the 2 bolt spacer plates that are in the kit, these are in 2 thicknesses, the 6mm and 4mm can be used consecutively.
10. At the back of the mount use the M12x65mm bolt, black 40mm OD x 4mm heavy duty washer and nyloc nut with the machined spigot from the back of the factory tow loop. You will need to use the large 4mm thick round washers that are also provided in the kit as spacers, the gap will determine how many washers you will use.
11. Once all bolts are in and the recovery point fitted snug do all bolts up, as per the specs below.

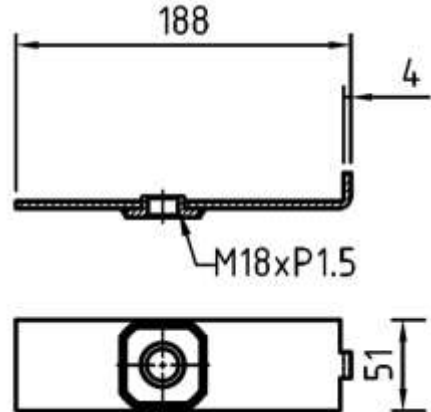

**HINT:**

Mark the end of the pin showing orientation of the threaded hole, this helps when its in the chassis and fitment of m12x140mm bolt from the front of the chassis.



*Australian Design Registration—201810098*

**Bolt Torque Specs**

	<b>8.8</b>	<b>10.9</b>	<b>12.9</b>
<b>M10</b>	41-60 Nm	59-85 Nm	65-94 Nm
<b>M12</b>	71-105 Nm	102-150 Nm	114-164 Nm
<b>M14</b>	112-168 Nm	161-240 Nm	182-265 Nm
<b>M16</b>	175-260 Nm	250-371 Nm	282-406 Nm

Step 5





**RP-PAT62**  
*Australian Design Registration—201810098*  
Nissan Patrol Y62  
**FEA Rated to 5000kgs**  
**per tow point**

Installation video can be found online at...

<http://roadsafe.com.au/4wd/fitting-instructions/>

**RP-PAT62 FITMENT GUIDE—Page 3**

**This shows fitment with ARB bar.**



Pic #6  
A brake away view of the M12x140 bolt in from the front of the chassis. This is missing the front chassis plate for illustration purposes.





**RP-PAT62**  
*Australian Design Registration—201810098*  
**Nissan Patrol Y62**  
**FEA Rated to 5000kgs**  
**per tow point**

### Fitting suppliment for Opposite Lock bar

The Opposite Lock bar requires a small cut to provide clearance for fitment of the RP-PAT62 points. Both sides are the same in a mirror image.

- Mark a line from corner A to corner B
- Measure up 30mm and mark a line parallel with the bottom edge.
- From the back edge measure in to the chassis and mark a line underneath in line with the edge of the chassis.
- The tow point will slide into this recess once removed.

