

Roadsafe – 3D Parts Design

Roadsafe Automotive, distributor of Australia’s largest range of Steering and Suspension components, have entered into the world of 3D parts design, keeping at the forefront of technology in their design and manufacturing processes.

Roadsafe have set up a partnership with WA based “3dmdesign” to aid in the design & development of the expanding front end range. The new 3D design technology far outweighs the old characteristics of the standard 2D CAD drawings. For example, the new 3D technology can turn a simple drawing on a piece of paper, into an ABS to scale model within just a couple of days!

Roadsafe are using the technology for two specific purposes. Firstly, to re-draw a large percentage of their range, enabling customers to view items in 3D on the website. The items can be twisted and moved to the required perspective, so the customer is able to see the item from any angle. Additionally and more importantly, the technology is being employed for the design and development of new products.

According to Tania Allatt, Roadsafe Product Marketing Manger, “One of the most exciting aspects of this new technology is being able to transfer an idea on paper into a working, test-fitable model. We can literally approve the drawing, have an ABS sample in a few days & test fit it to a vehicle in a timely manner.”

The new 3D drawing artwork is also quite amazing. As Tania explains “we are able to effectively ‘explode’ the view of an item to see all the inner workings. So for a drag link that has various components from rod to ends with internal components such as ball stud, boot, spring, even down to the grease nipple and nut, we are able to pull the entire assembly apart, piece by piece, and analyse each component individually – then put it back together and see how it all fits”.

Old Style 2D drawing...

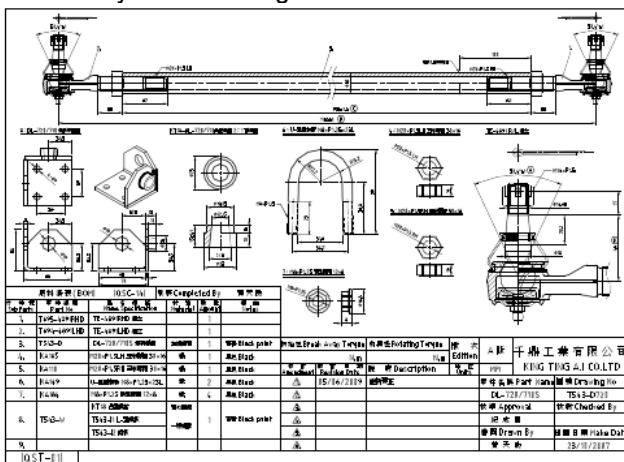

New style 3D drawing...

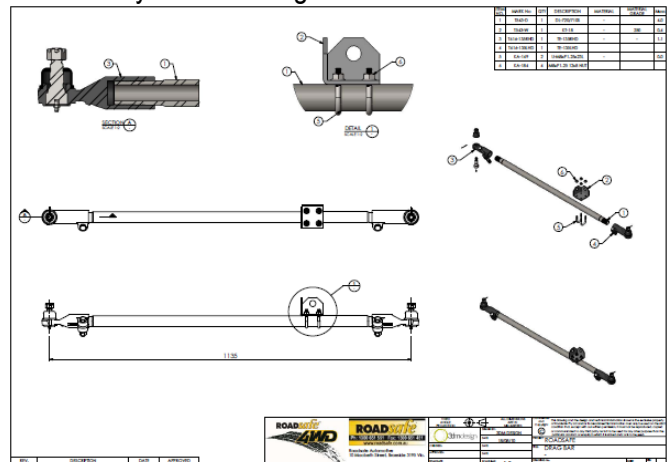

Some of the key features of the new 3D design technology include:

PART MOCK-UPS

With mock-ups made on a 3D printer, the product can be seen before ever going into production. Models can be made within hours and then sanded, painted, tapped and drilled - even chrome plated - to give a reliable representation of the actual manufactured product.

Mock-ups also allow the observation of design flaws and make the appropriate adjustments early and often throughout the design process. A 3D printed part could pay back initial investments just by catching a design flaw before a product goes into production, saving companies lavish retooling and/or reworking costs.

FUNCTIONAL TESTING

3D printers create models of ABS plastic that are tough enough to be used as working parts. Durable ABS models enable you to test form, fit and function - through as many design alterations as reasonably needed.

Compared to models produced with photo chemicals, wax or other forms of prototyping, ABS models provide a higher level of precision. Pieces actually snap or fit together. ABS allows you to build durable and functional models that can withstand rigorous testing, holding their tolerances for years.

ABS models can be drilled, tapped, sanded and painted. ABS is the most commonly used thermoplastic in manufacturing today, used in mobile phones, television sets, and the majority of car interiors.

COST REDUCTION

There are dozens of costs involved in developing a new product. Poor communication, extensive changes and missed deadlines can increase those costs exponentially throughout each step of product design and development.

3D printers help the design team to reduce those costs with better communication, collaboration and design verification throughout the process.

MARKETING TOOLS

3D models are great marketing tools. ABS model can be sanded, painted - even chrome-plated - to match the finished appearance of a new product. Imagine showing prospects a pre-launch model of a new product that's nearly identical to the real thing. They can see it, hold it, examine it from every angle. And with 3D printing, you can produce this kind of high-level product model in a few days - an impressive way to present your very latest concepts.

Have you ever seen a tie rod end that is only 25mm long? Roadsafe have just had one printed in ABS. The ABS printing process is a major process, but is absolutely amazing. From small scale samples (hence the 25mm tie rod end!) to full scale replica copies – the uses are just endless.

“You think in three dimensions. Your products are three-dimensional. So it makes sense to design them in 3D” Tania said.

Please refer to the website to view a sample of the 3D animated artwork...www.roadsafe.com.au

Additional information regarding the 3dmdesign technology can be obtained from either:

Roadsafe – 1300 651 551 (or email sales@roadsafe.com.au)

3dmdesign – (email info@3dmdesign.net)

